

Installation Instructions

Holywell Plus Plug & Play Batten

Input	220-240V AC
Power	18/36-25/50-28/56W
Operating Temp	0°C--+40°C
Connection Type	Push Fit Terminal
Emergency Option	430962 (Sold Separately)
Control Connection	430916 (Sold Separately)
Light Source Energy Rating	B



Dimensions:

Part No.	Description	L (mm)	W (mm)	H (mm)	LF (mm)	Weight
431291	Holywell Plus 18W/36W 4ft Twin	1203	64	66	880	1.4Kg
431292	Holywell Plus 25W/50W 5ft Twin	1503	64	66	1180	1.7Kg
431293	Holywell Plus 28W/56W 6ft Twin	1803	64	66	1480	1.7Kg

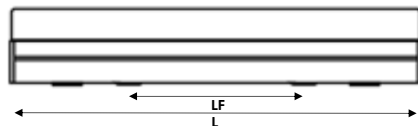
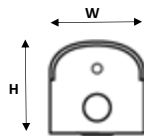

End Of Life Disposal:

Disassembly instructions for end of life disposal available on website.
 Disposal of Electronic Equipment WEEE Directive 2002/96/EC This product falls within the scope of the Waste Electrical & Electronic Equipment Directive (WEEE), which means the product should not be disposed of as normal household waste. Please recycle where facilities exist or check with your Local Authority. RoHS - All components and materials used in this product are RoHS 2002/95/EC compliant. Specifications may change from time to time. The information contained in this leaflet is for guidance only and should not be considered as always accurate and should be treated as not representative.

Box Contents:

- Holywell Batten
- Fixing Kit

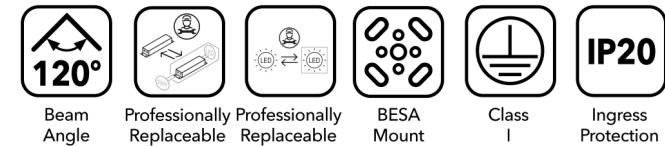

Tools Required For Installation:

- Wire Strippers / Cutters
- Screwdriver
- Drill



READ THESE INSTRUCTIONS THOROUGHLY BEFORE INSTALLATION

KEEP THESE INSTRUCTIONS FOR FUTURE REFERENCE.

IMPORTANT:

This product must be installed by a qualified electrician or competent person, and in accordance with current building and IET wiring regulations.

Warranty:

This luminaire is warranted for a period of 5 Years from the date of purchase**. The warranty could be invalidated should the light fitting not be installed according to these instructions, outside the scope of the specification or the product has been altered or tampered with in any way. Please see website for terms and conditions.



WARNING: Risk of electric shock!
Isolate the mains power before proceeding.

- Turn off the mains power before performing inspections, installation, or removal
- Verify that the supply voltage is correct by comparing it with the luminaire label information
- It is the installers responsibility to ensure installation is suitable for the total load of the luminaire(s). The supply cable, fuses/circuit breakers must be correctly rated for the electrical load and considering for any transient inrush currents that may occur.
- Do not perform insulation strength or resistance tests on installed luminaire(s) connected

Installation Procedure:

1. Disconnect the mains supply.
2. Install the batten in desired location.
3. Connect mains to terminal block as indicated—Standard version.
4. Connect mains to terminal block as indicated—Emergency version.
5. Select required wattage via dip-switch on LED driver.
- 5a. Select colour temperature via switch located in product base.

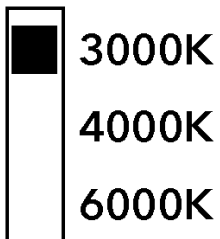

6. Re-fit the diffuser and use screws provided to secure into position.
7. Reconnect the mains supply.

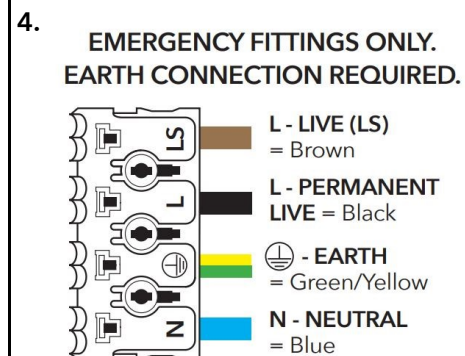
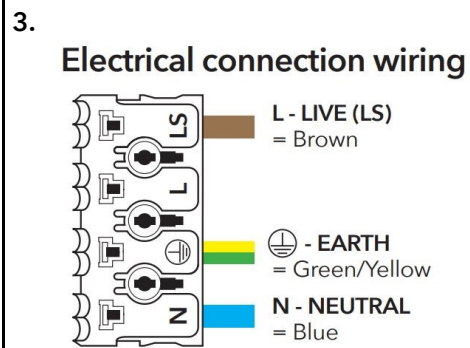
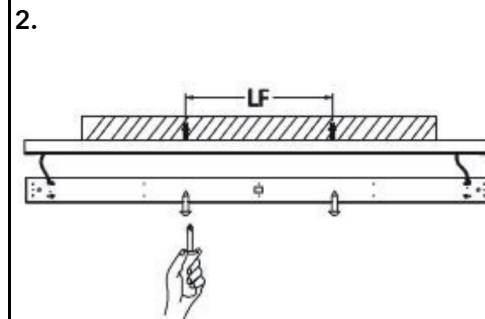
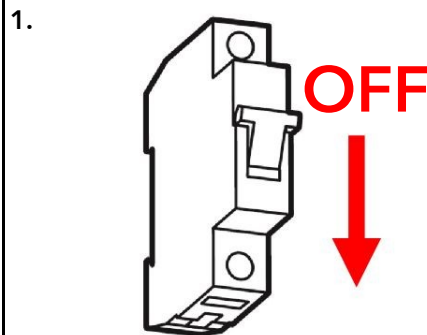

5.

	4ft	5ft	6ft			
	Watts	Wattage Select	Watts	Wattage Select	Watts	Wattage Select
Higher Wattage ↑ ON ↓ Lower Wattage	18W		25W		28W	
	36W		50W		56W	

